

## Inkjet printer SIJ-320UV

# Requests for Daily Care and Maintenance

This machine is a precision machine equipped with extremely fine mechanisms. Especially, the nozzle surface of the heads from which the ink is discharged is affected even by a slightest attachment of dust or paper powder and the proper printing results could not be obtained. With a view to using this machine in a better condition, we would like to recommend performing the following care and maintenance on daily basis.

### 1. When to care

When to care	What to care	Reference Page
Once a day (at the end of the daily work)	Surroundings of the heads	P.2
	Capping station	P.3
	Wiper	P.4
	Wiper cleaner	P.4
	Media press	P.5
	Media sensor	P.5
	Waste ink tank	P.5
Once a week (at the end of the work on weekend)	Cleaning the Platen	P.6
	Exterior	P.6
Once in a month	Replacing the H fan filter	P.7
When replace the ink tank	Replacing the ink filter	P.8



■ Tools required for maintenance

- Cleaning stick (SPC-0527)
- Washing liquid for maintenance (SPC-0568)
- Cotton swab
- Gloves
- Soft fabric



- Make sure to wear the attached **goggles and gloves**.

## 2. Daily care



- When possible, use the cleaning stick (SPC-0527) for cleaning around the head/ capping station/ wiper. Using the other cotton bud may attach lint, then it may damage the machine.
- Be sure to perform maintenance for the ink cap and the wiper of capping station every day. If you leave it dirty, dirt may adhere to the nozzle surface, or, dust and dry ink may be rubbed against the nozzle. It may cause discharge defect.
- Clean the bottom of carriage every day so that it will not get dirt from inks or dusts. If you leave it dirty, dust and dry ink may be rubbed against the nozzle at wiping operation when performing head cleaning.
- When you clean the carriage bottom surface, fully be careful not to rub the nozzle surface.

### (1) Surroundings of the heads ("Cleaning the Head and the Area around It" Chapter 4 of the Operation Manual)

**Important!**

- The heads and their surroundings are the parts most liable to be tainted in this machine and if tainted, it could cause adverse effects to the functions of the machine and the results of the printings. Moreover, as the head itself uses very fine mechanisms, sufficient precautions are required for the care and maintenances.

#### 1 Move the carriage to the left and open the left maintenance cover.

- Refer to the Step 1 to 5 of Chapter 4 "Cleaning the Head and the Area around It" of the user's manual to perform the operation.

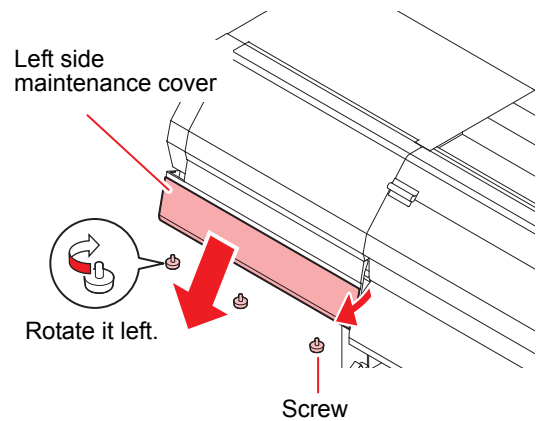

#### 2 Clean the head and the surrounding area.

- Gelled ink and dust could stick under the slider and the surroundings of the head.
- Scrape them off with clean stick etc. In this case, never rub the nozzle portion of the head.

Clean the side surface of the head (shown in deep gray) with a clean stick.

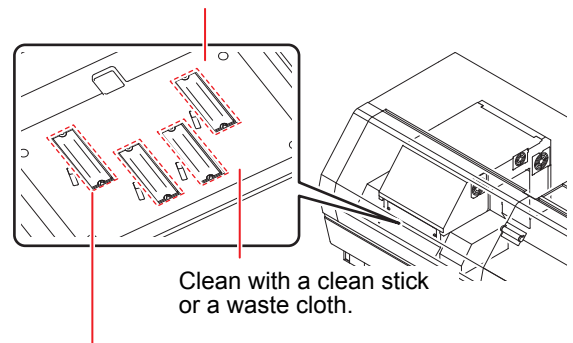

#### 3 Clean the bottom surface of the UV lamp.

- If there is any ink stuck on the rear side of the bottom surface of the UV lamp, apply the cleaning solution for maintenance to a clean stick and wipe the ink away. Wipe off so that cleaning solution for maintenance will not remain.

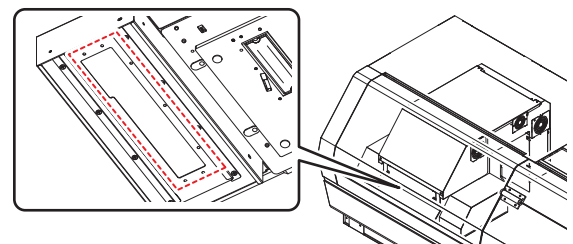

## (2) Capping Station ("Cleaning the Wiper and Cap" Chapter 4 of the Operation Manual)

The surrounding area of the cap is also liable to be stained by the dust and ink. It is recommended to clean the head frequently using the cleaning liquid for maintenance suitable for the ink used to avoid the stains on the head.

- Washing liquid for maintenance (SPC-0568)

### 1 Move the carriage and open the right side maintenance cover.

- Refer to the Step 1 to 4 of Chapter 4 "Cleaning the Wiper and Cap" of the user's manual to perform the operation.

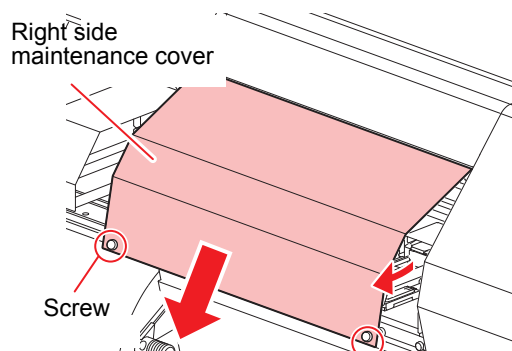

### 2 Clean the cap rubber and cap rubber cover.

- Wipe off the ink sticking to the cap rubber and cap rubber cover with a clean stick dipped in cleaning solution for maintenance.  
Wipe off so that cleaning solution for maintenance will not remain.

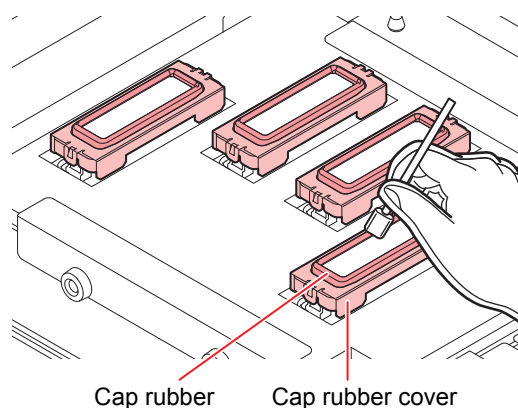

### (3) Wiper ("Cleaning the Wiper and Cap" Chapter 4 of the Operation Manual)

On the wiper, the ink, dust and paper powder are liable to accumulate. Check the state of the wiper and if it is stained, clean it.

#### 1 Move the carriage and open the lower right maintenance cover.

- Refer to the Step 1 to 4 of Chapter 4 "Cleaning the Wiper and Cap" of the user's manual to perform the operation.

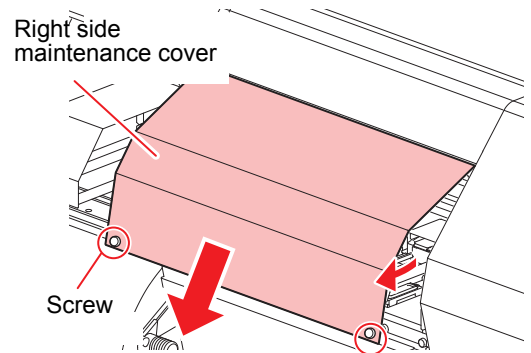

#### 2 Clean the wiper.

- Remove the wiper by holding the protrusions at its both ends.
- Wipe off the ink sticking to the wiper and bracket with a clean stick dipped in cleaning solution for maintenance. Wipe off so that cleaning solution for maintenance will not remain.

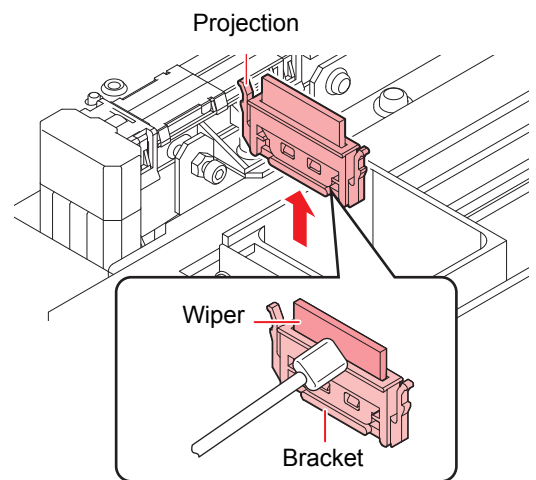

Further, in the cases as explained below, replace the wiper with the new one (SPA-0193) in accordance with "Replacing the wiper" on Chapter 4 of the Operation Manual.

- When the wiper is deformed
- When the stuck ink can not be wiped off
- When the warning for wiper replacement is indicated

#### (4) Clean the wiper cleaner

Wipe off the ink of the wiper cleaner with clean stick or waste cloth dipped in cleaning solution for maintenance.

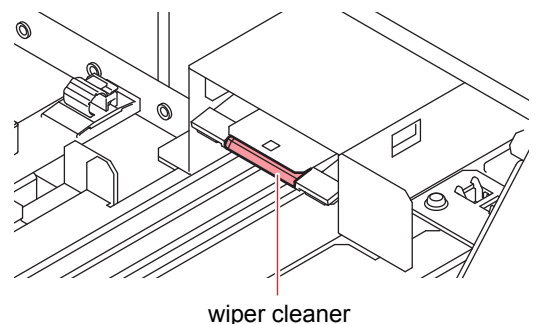

### (5) Media press ("Cleaning the Media Press" Chapter 4 of the Operation Manual)

When the cut dust of the media and other dusts accumulate between the media holder and the platen, it could cause the risks that the transfer of the media could not be performed properly or such dusts stick to the nozzles and this could interfere the proper printings. You are recommended to clean it frequently.

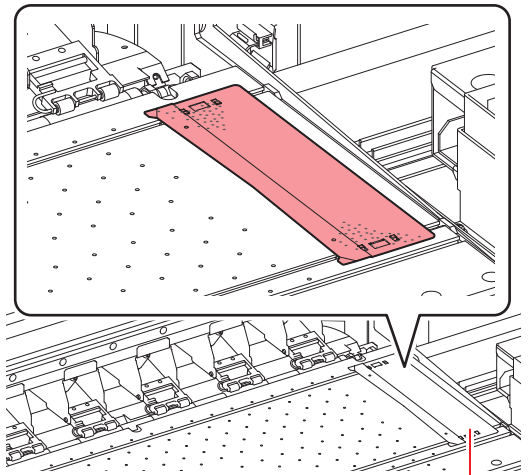

Media press

### (6) Media sensor ("Cleaning the Media Sensor" Chapter 4 of the Operation Manual)

The media sensors are located on the platen (for two positions) in the backside and the bottom surface of the head.

If the dusts and ink accumulate on the sensor, it could cause false detection of the media or the register mark. Wipe off the sensors with soft cloth or clean sticks.



- For the cleaning of the media sensors, never use the solvent.
- When the sensor is heavily stained, wipe off with a cloth soaked in the waterdiluted neutral detergent.
- When cleaning the media sensor at the bottom of the head, be cautious of the cutter blade near the sensor to avoid injuries.

The backside of the machine

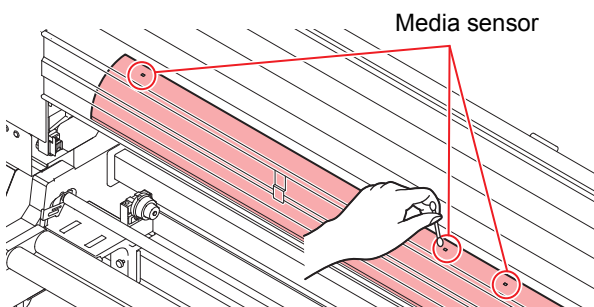

The lower surface of the head

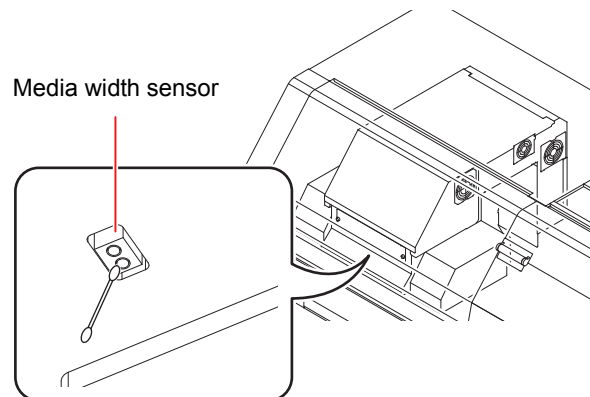

### (7) Waste ink tank ("Discarding waste ink" Chapter 4 of the Operation Manual)

- 1 Refer to the Chapter 4 "Discarding waste ink" of the user's manual to perform the operation.

### 3. Periodically care (Once a week)

Users are advised to perform the maintenance works described below once a week so that the printer will keep its high performance and accuracy over an extended period of its life.

#### (1) Platen (“Cleaning the Platen” Chapter 4 of the Operation Manual)

Platen is a place where dusts, paper powder, and ink are liable to accumulate. It is therefore suggested to clean it frequently. Wipe out the platen surface and the platen cover with a soft brush or cloth. The grooves for media holder and for cutting the paper (cutter line) are the place where the dusts are especially liable to accumulate. Clean them thoroughly.

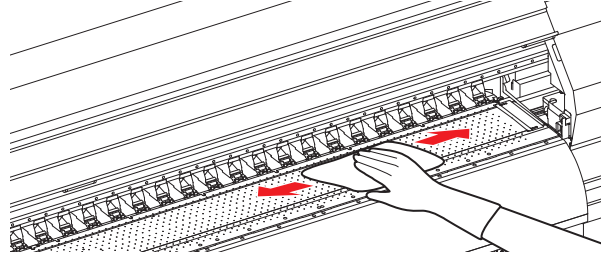

#### (2) Exterior (“Cleaning the Exterior Surfaces” Chapter 4, Operation Manual)

Depending on the using environment, the dusts or sand powder could stick to the exterior of the main unit. To avoid the entry of the dusts into the moving part of the head, wipe them off with soft cloth dipped into water and squeezed tightly.

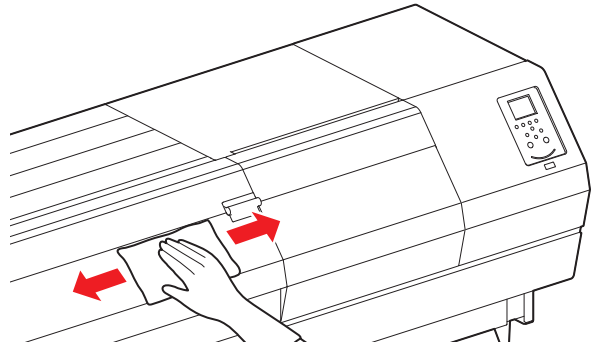

## 4. Periodically care (once in a month)

### (1) Replacing the H fan filter

Replace it once in a week or two weeks.

#### 1 Move the carriage and open the rightside maintenance cover.

- Refer to the Step 1 to 4 of Chapter 4 “replace the H fan filter” of the user’s manual to perform the operation.

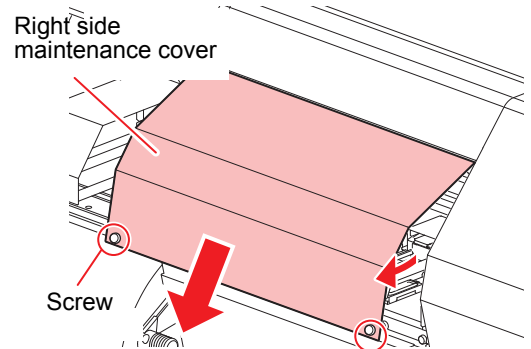

#### 2 Remove the H fan filter cover at the right side of the carriage.

- Remove the screw on the H fan filter cover before removing the cover.

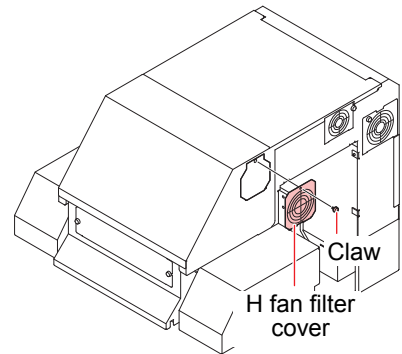

#### 3 Remove the used H fan filter cover.

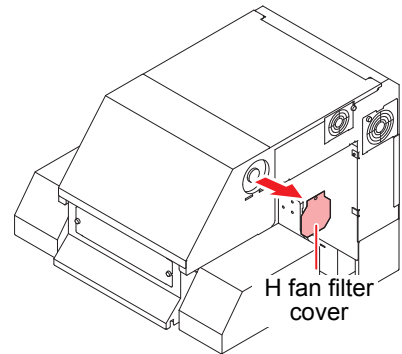

#### 4 Mount a new H fan filter (SPC-0766).

- Align the hole in the H fan filter with the screw hole.

#### 5 Return the H fan filter cover to the original status.

#### 6 Close the right side maintenance cover, and press the **ENTER** key.

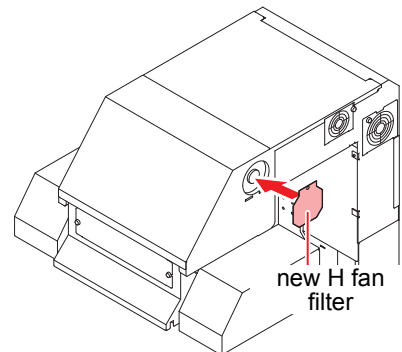

**Important!**

- Ink at printing adheres to the H fan filter ASSY. When replacing the filter, it is recommended to perform the work with a sheet of paper placed.

## 5. Replacing the ink filter (When replace the ink tank)

To keep the ink in good quality in the ink tank, you need to replace the ink tank annually. When an appropriate warning message appears, be sure to replace tank in the following procedure:

**1** Press the **FUNC1** (MENU) in LOCAL.

**2** Press **▲▼** to select [Maintenance], and press the **ENTER** key.

**3** Press **▲▼** to select [Replace Ink Tank], and press the **ENTER** key.

**4** Press **▲▼** to select a desired ink tank, and press the **ENTER** key.

- The display shows a confirmation screen prompting to replace the ink tank and the type and the expiration date (year and month) of the ink contained in the ink tank to be replaced.

**5** If there is no problem on the confirmation screen, press the **ENTER** key.

- This resets the ink charge information embedded in this machine.

**6** Remove the ink maintenance cover for the ink tank selected in step 4.

- Loosen the screws attached to the ink maintenance cover both sides, remove the screw that is attached to the top surface.

**7** Replace the ink tank.

- Cover the surrounding area with waste cloth for protection against dirt before changing the ink tank.

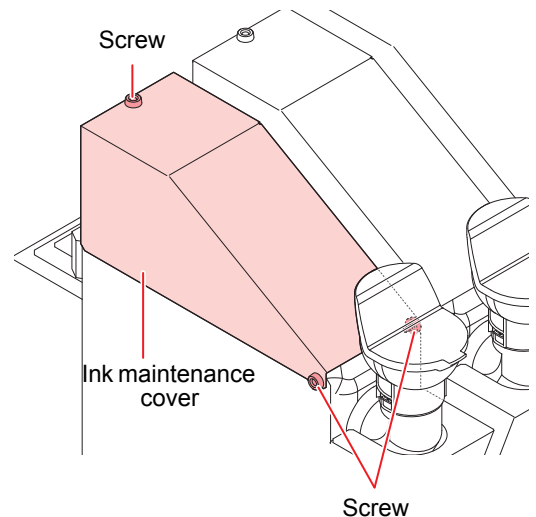

**(1) Remove the ink filter attached to the ink tank.**

- Loosen the joints on the top of the ink filter, and remove the filter.

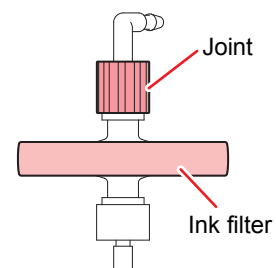



**(2) Remove the ink tank.**

- Take care not to tilt the ink tank greatly when removing the tank. It may cause ink leakage from the cap.

**(3) Set a new ink tank, and mount the ink filter.**

- Tighten the joints on the bottom of the ink filter.

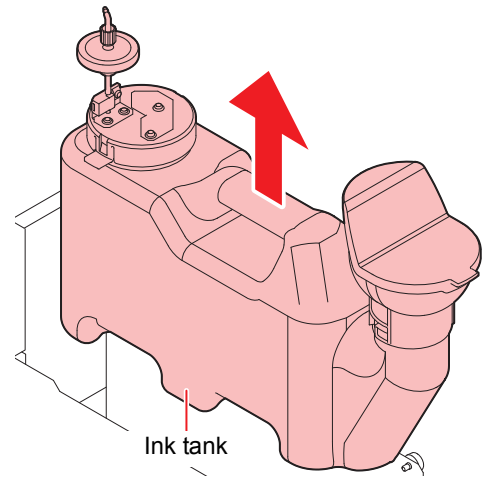

- Do not pour the ink remaining in the removed ink tank into the new tank.
- Request that an industrial waste disposal company process the disposal ink.
- When the tube and cover are in contact, there are times when the amount of ink can not be accurately detected. So as not to contact to the utmost as shown in the figure below, please be careful for the direction of the joint.

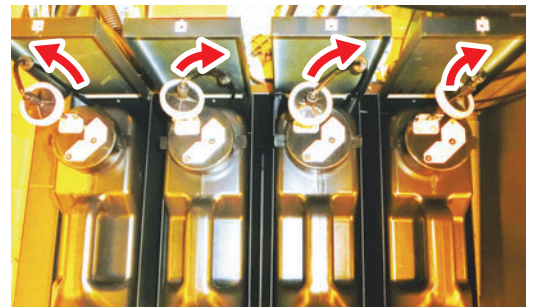

**8** Refer to the Chapter 1 “Fill ink in the ink tank and charging” of the user’s manual to perform the operation., and refill with new ink.

## 6. Storage of media

Media should be stored in the little dust area, and not in direct sunlight. Avoid storing the media in the area with high temperature and high humidity.

## 7. Storage of ink bottle

Be careful of the followings to store.

- Store the ink bottle in no direct sunlight, and no high humidity.
- As it's a delicate product, do not drop it.
- Ink IC should not be contaminated and discharged static electricity.
- Be sure to store the ink bottle and the ink IC together.



Ink bottle and Ink IC

## 8. The examples of defective printing

These following examples indicate improper head (nozzle) firing by dust, which effect printing.

Confirm the nozzle condition periodically before or during outputting not to use in such as this condition.

The nozzle condition can be confirmed with [test printing] in this plotter. (Operation manual Chapter 2 “Test Printing”)

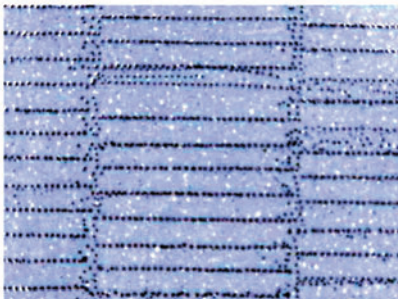

1. Deflection



2. Nozzle out



3. Ink dropping



4. Satellite

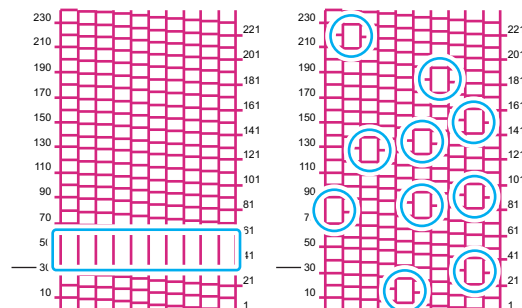

5. Mixing in air

## 9. Recovery method of defective nozzle discharge

When this printer has not been used for an extended period of time, or depending on the environmental temperature, the discharge at the nozzles could become unstable. In such a case, the following methods may be taken to recover the status of the nozzles.

### For symptoms 1 to 4 in P.10 “The examples of defective printing”

#### 1. Daily maintenance and care

- Perform the cleaning of the parts described in this document.

#### 2. Performing Head Cleaning (normal). Refer to Chapter 2 of Operation Manual.

- After having performed the care and maintenance stated in step 1, perform the cleaning of the heads in accordance with the procedures stated in Operation Manual.

#### Perform test printing and check

(Chapter 2 of Operation Manual)

In the event nozzle missing etc. have not been improved

#### 3. Performing Head Cleaning (hard). Refer to Chapter 2 of Operation Manual.

- If the nozzle missing does not disappear even after repeating the head cleaning (normal) several times, reset the cleaning mode to "hard" and perform the cleaning again.

#### Perform test printing and check

(Chapter 2 of Operation Manual)

In the event nozzle missing etc. have not been improved

#### 4. Set the nozzle recovery function. Refer to Chapter 4 of Operation Manual.

- Set the nozzle recovery function.

#### Perform test printing and check

(Chapter 2 of Operation Manual)

### For symptoms 5 in P.10 “The examples of defective printing”

#### 1. Daily maintenance and care

- Perform the cleaning of the parts described in this document.

#### 2. If nozzle missing due to color mixture of ink or aeration Refer to Chapter 5 of Operation Manual.

- Perform air removal according to the procedure in the Operation Manual.

#### Perform test printing and check

(Chapter 2 of Operation Manual)



- If the nozzle missing has not been improved even with the above operations, please call us or your sales agent from whom you purchased this printer.

## 10. Supplies

Name of part	Part codes
UV ink LUS-120 Black ink (1 liter bottle)	I-Lus12-K-BA-I-KW
UV ink LUS-120 Cyan ink (1 liter bottle)	I-Lus12-C-BA-I-KW
UV ink LUS-120 Magenta ink (1 liter bottle)	I-Lus12-M-BA-I-KW
UV ink LUS-120 Yellow ink (1 liter bottle)	I-Lus12-Y-BA-I-KW
H fan filter	SPC-0766
Clean stick for the surroundings of the head 50pcs	SPC-0527
Maintenance washing liquid	SPC-0568
Wiper kit	SPA-0193
Air purge jig kit	SPA-0264
Cap ink absorber kit	SPA-0263
Waste ink tank	SPA-0265
3L ink bottle	SPA-0266

## 11. Safety Precautions

### CAUTION



Make sure to wear the attached **goggles and gloves**.



The ink, if mixed with water or alcohol, generates condensed substances. Pay attention not to deposit water or alcohol to the nozzle surface, surrounding area of the heads, caps and wipers.



To secure the stability of the ink discharge, when the printer is not used (output) for an extended period of time, it could become necessary to discharge periodically a small amount of ink (flushing), depending on the kinds of the ink.

**When not using for an extended period of time, put off the power switch on the front, only. Leave the main power switch at the side of the equipment on and keep the cable socket inserted into the plug.**



**Make maintenance after the LED UV has been sufficiently cooled, or burn injury may occur.**



**Never disassemble this machine. It could cause electrical shock, fire and breakage.**



**Keep away the moisture from the inside of this machine. If the inside is moistened, it could cause electrical shock, fire and breakage.**



**Perform the maintenance and care after switching off the power and taking off the power cable. Otherwise, it could cause unexpected accidents.**



**Avoid using benzene, thinner, and chemicals containing abrasive compounds. The surface of the cover could be degenerated or deformed.**



**Do not supply lubricant oil etc. to the inside this machine. It could cause the breakdown of this machine.**

## 12. Installation environment

- Use this printer as much as possible in a dust-free environment. Fans and air-blowers could cause the dustspewing.
- The using environment of this printer is from 20 to 30°C (68°F to 86°F) in temperature and from 35 to 65 % in relative humidity. Avoid the use of this printer at a temperature and humidity higher or lower than the indicated ranges.







**You can also download the latest manual from our website.**

© 2015 MIMAKI ENGINEERING CO., LTD.

D202811-10-02042015

NH

FW :1.20